

# Impaq Plus-W

## INSTALLATION INSTRUCTIONS

### INTRODUCTION

- For wireless connectivity, detailed programming and system set-up instructions please refer to the compatible RICOCHET™ technology enabled Premier wireless expander instructions.
- Featuring RICOCHET™ wireless technology the Impaq Plus-W is designed for professional security installations.

### MOUNTING POSITIONS

Fig.1

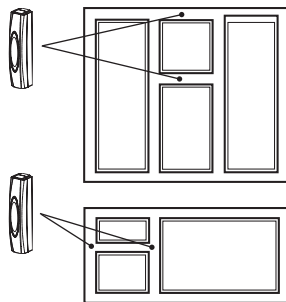
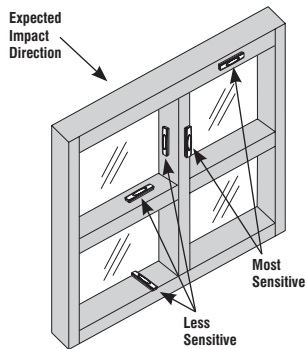

Fig.2



### ASSEMBLY

For rear tamper - fix both the detector AND the rear tamper insert to the mounting surface. Activation of rear tamper will damage product.

#### Rear Tamper Insert

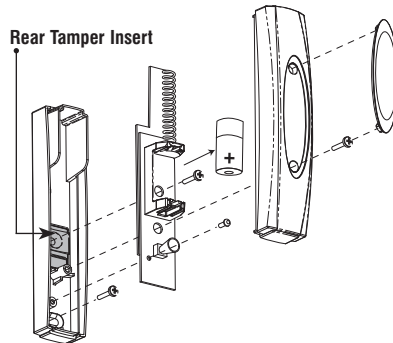

### SENSITIVITY SET-UP

The Impaq Plus-W can be installed in any orientation but for maximum sensitivity position as shown in Fig.2. Once mounted the sensitivity should be carefully calibrated using range jumper and the sensitivity adjustment.

1. When the unit is first powered the LED will light green for approximately 10 seconds while the unit self-calibrates.
2. Enable walktest LED functionality using wireless monitor/Wintex. To set the sensitivity turn the sensitivity adjustment to minimum (anti-clockwise) and firmly tap the middle of the area to be protected. If the LED lights red or orange, remove the "Range Select" jumper to select the "low sensitivity" range. Gradually increase the sensitivity by turning the sensitivity adjustment clockwise. After each adjustment, firmly tap the area and observe the LED colour. A red LED indicates that the sensitivity is correct. If the LED turns green, the sensitivity is too low and needs increasing. If however the LED turns orange, the sensitivity is too high and needs reducing.
3. Replace the cover and tighten the fixing screw. Press the cover into the lid and confirm the desired impact response.

## Battery

Only replace with 3V Lithium CR123A.

### Battery Safety

- Do not throw into a fire
- Do not heat
- Do not charge
- Do not short circuit
- Do not disassemble
- Replace only with same or equivalent type
- Always observe local regulations when disposing of a battery
- Detector will transmit low battery warning when battery needs replacing

### Magnet

#### Non-Ferrous Mounting Material

- Maximum Break = 30mm
- Minimum Make = 15mm

#### Ferrous Mounting Material

- Maximum Break = 15mm
- Minimum Make = 5mm

Note: Values depend on mounting material

### Reed Disable

	Disabled
	Enabled

### Range

	High Range
	Low Range

### Sensitivity Adjust

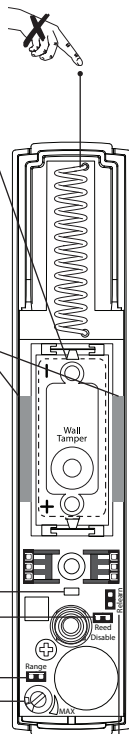

### Relearn

Place jumper on Relearn pin header and insert battery to learn device.

## LED STATUS INDICATION

Only available in walktest mode

(See Premier wireless expander instructions)

<b>Flashing Green:</b>	Comfort LED. When the reed switch is closed, the comfort LED will flash green approximately every 3 seconds to indicate correct operation.
<b>Momentary Green:</b>	Background disturbance/under-sensitive setting. This is used to indicate background disturbances or an under-sensitive setting during installation.
<b>Momentary Red:</b>	Alarm condition/correct sensitivity. This is used to indicate that an attack has been detected by the shock sensor or a correct sensitivity setting during installation.
<b>Momentary Orange:</b>	Gross attack/over-sensitive condition. This is used to indicate that a massive attack has been detected by the shock sensor or an oversensitive setting during installation.

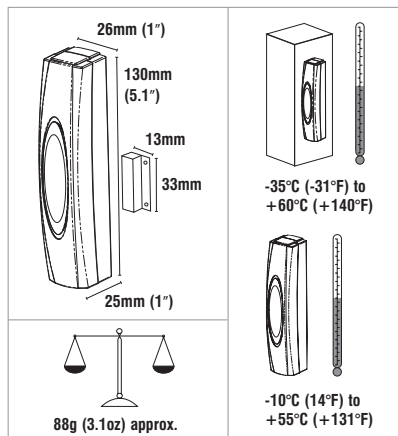

## STANDARDS

<b>Alarm Systems:</b>	EN50131-2-6, EN50131-5-3, EN50131-1, PD6662 Grade 2 Class II
<b>EMC:</b>	EN50130-4:1995, A1: A2, ETSI EN301 489-03 V1.4.1
<b>R&amp;TTE:</b>	ETSI EN300-220 (V2.1.1)
<b>Environmental:</b>	EN50130-5
<b>Frequency Band:</b>	868.0 - 868.6 MHz / 433.05 - 434.79 MHz

## WARRANTY

2 year replacement warranty (excludes battery).

The *Impaq Plus-W* is designed to detect the vibrations caused by an intruder attempting to force an entry, or the opening of a door/window and activate an alarm control panel. As the *Impaq Plus-W* is not a complete alarm system, but only a part thereof, Texecom cannot accept responsibility or liability for any damages whatsoever based on a claim that the *Impaq Plus-W* failed to function correctly.

Due to our policy of continuous improvement Texecom reserves the right to change specification without prior notice. All specifications are measured at 20°C (68°F).



Made In England

HALMA GROUP COMPANY



Certificate Number: FM 35285

Impaq and the wireless logo are trade marks of Texecom Ltd. © 2010

The *Impaq Plus-W* is protected by European Registered Design. No: 269188-0001 A20110401 INS512-2